

ORGANIZATIONAL MAINTENANCE MANUAL

TABLE OF
CONTENTS
III

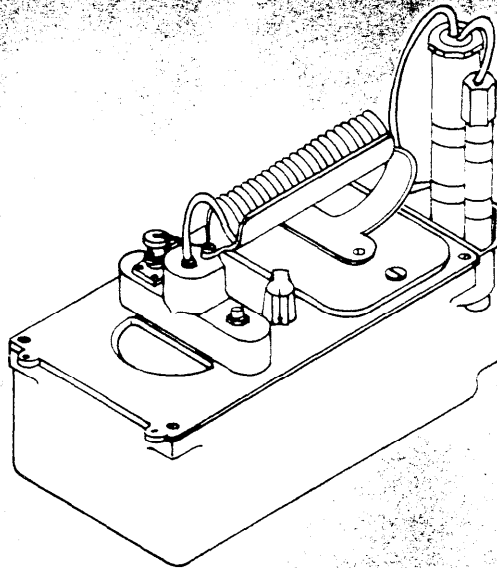

CHAPTER 1
INTRODUCTION
1-1

CHAPTER 2
MAINTENANCE
INSTRUCTIONS
2-1

APPENDIXES
A-1

GLOSSARY
G-1

RADIAC SETS

AN/PDR-27J (NSN 6665-00-543-1435)
AN/PDR-27L (NSN 6665-00-865-3456)
AN/PDR-27Q (NSN 6665-00-017-8903)

HEADQUARTERS DEPARTMENT OF THE ARMY

12 MARCH 1981

WARNING
RADIATION HAZARD-KRYPTON 85

Test Sample used in this equipment is **RADIOACTIVE** and contains 5 millicuries of Krypton 85.

DO NOT:

Handle the test sample by the active (colored) end.
Place the test sample next to your skin.

DO:

Keep the test sample in the case when not in use. Assure that the test sample is securely attached to the radiac set case with the chain provided. Handle only as necessary.

WARNING

Spare tubes are not supplied or issued with the Radiac Set. Should you receive spare tubes by mistake, return to stock immediately. Never attempt to replace a tube in the radiacmeter. Injury may result.



Refer to TM 3-6665-264-10 for specific instructions on the control, safe handling, inspection, storage, and disposition of the test sample.

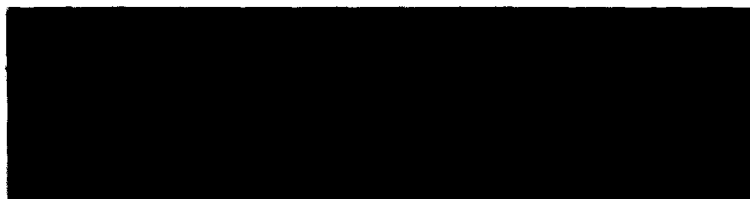

This manual covers the organizational maintenance of Radiac Sets AN/PDR-27J, AN/PDR-27L and AN/PDR-27Q. Official nomenclature followed by (*) is used to indicate all models of the Radiac Set referenced in this manual. Thus, Radiac Set AN/PDR-27(*) represents Radiac Sets AN/PDR-27J, AN/PDR-27L and AN/PDR-27Q.

In this manual, the paragraphs are numbered for easy reference. If you are looking for specific information, use the Table of Contents at the front of the manual to locate the paragraph and page where the topic is discussed.

ORGANIZATIONAL MAINTENANCE MANUAL

RADIAC SETS

AN/PDR-27J (NSN 6665-00-543-1435),
AN/PDR-27L (NSN 6665-00-856-3456),and
AN/PDR-27Q (NSN 6665-00-017-8903)

REPORTING OF ERRORS AND RECOMMENDING IMPROVEMENTS

You can help improve this manual. If you find any mistakes or if you know of a way to improve the procedures, please let us know. Mail your letter, DA Form 2028 (Recommended Changes to Publications and Blank Forms), or DA Form 2028-2 located in back of this manual direct to: Commander, US Army Communications and Electronics Materiel Readiness Command, ATTN: DRSEL-ME-MQ, Fort Monmouth, New Jersey 07703. A reply will be furnished to you.

This manual supersedes so much of TM 11-6665-209-15 2 September 1960, including all changes that pertains to the Organizational Maintenance.

TABLE OF CONTENTS

CHAPTER 1 INTRODUCTION

		Paragraph	Page
Section 1	General Information		
	Scope	1-1	1-1
	Maintenance forms, records and reports	1-2	1-1
	Destruction of Army materiel to prevent enemy use	1-3	1-1
	Preparation for storage and shipment	1-4	1-1
	Nomenclature cross-reference list	1-5	1-2
	Reporting equipment improvement recommendations (EIR)	1-6	1-2



	Paragraph	Page
Section II.	Equipment Description and Data	
	Equipment characteristics, capabilities and features	1-7
	Location and description of major components	1-8
	Differences between models	1-9
	Equipment data	1-10
Section III.	Principles of Operation	
	Central	1-11
	Block diagram description	1-12
CHAPTER 2 MAINTENANCE INSTRUCTIONS		
	Tools, repair parts, and special tools	2-1
	Checking unpacked equipment	2-2
	Service upon receipt	2-3
	Preventive maintenance checks and services (PMCS)	2-4
	Troubleshooting	2-5
	Replacement of parts	2-6
	Maintenance procedures	2-7
	Preparation for storage and shipment	2-8
APPENDIX A.	REFERENCES	A-1
B.	MAINTENANCE ALLOCATION CHART	B-1
C.	EXPENDABLE SUPPLIES AND MATERIALS LIST	C-1
	GLOSSARY	G-1

SECTION I
GENERAL INFORMATION
CHAPTER 1
INTRODUCTION

1-1. SCOPE

Type of Manual:	Organization Maintenance
Model Number and Equipment Name:	AN/PDR-27J, AN/PDR-27L and AN/PDR-27Q; Radiac Sets.
Purpose of Equipment:	Detects and measures beta and gamma radiation together of gamma radiation alone.

1-2. MAINTENANCE FORMS, RECORDS, AND REPORTS

- a. Reports of Maintenance and Unsatisfactory Equipment
Department of the Army forms and procedures used for equipment maintenance will be those prescribed by TM 3-8-750, The Army Maintenance Management System.
- b. Report of Packaging and Handling Deficiencies
Fill out and forward SF 364 (Report of Discrepancy (ROD)) as prescribed in AR 735-11-2/DIAR 4140.55/ NAVMATINST 4355.73/AFR 400-54/MCO 4430.3E.
- c. Discrepancy in Shipment Report (DISREP) (SF 361)
Fill out and forward Discrepancy in Shipment Report as prescribed in AR 55-38/NAVSUPINST 4610.33B/AFR 75-18/MCO P4610.19C and DLAR 4500.15.

1-3. DESTRUCTION OF ARMY MATERIEL TO PREVENT ENEMY USE

For instructions for the destruction of Army material to prevent enemy use refer to TM 750-244-2.

1-4. PREPARATION FOR STORAGE AND SHIPMENT

For instructions on storage and shipment of Radiac Sets AN/PDR-27(#) refer to chapter 2, Maintenance, paragraph 2-7.

1-5. NOMENCLATURE CROSS REFERENCE LIST

COMMON NAME	OFFICIAL NOMENCLATURE
Radiac Set	Radiac Set AN/PDR-27J or Radiac Set AN/PDR-27L or Radiac Set AN/PDR-27Q
Radiacmeter	Radiacmeter IM-141/PDR-27J or Radiacmeter IM-173/PDR-27L or Radiacmeter IM-195/PDR-27Q
Harness	Harness, ST-136/PDR-27J
Headset	Headset, Electrical H-43/U
Case	Case, Carrying CY-2312/PDR-27J
Test Sample	Radioactive Test Sample, MX-7338/PDR-27R
Battery	Battery, Dry BA-30
Probe	Probe, DT-196/PDR-27J

1-6. REPORTING EQUIPMENT IMPROVEMENT RECOMMENDATIONS (EIR)

EIR can and must be submitted by anyone who is aware of an unsatisfactory condition with the equipment design or use. It is not necessary to show a new design or list a better way to perform a procedure, just simply tell why the design is unfavorable or why a procedure is difficult. EIR may be submitted on SF 368 (Quality Deficiency Report). Mail directly to: Commander, US Army Communication and Electronics Materiel, Readiness Command, ATTN: DRSEL-ME-MQ, Fort Monmouth, New Jersey 07703. A reply will be furnished directly to you.

SECTION II EQUIPMENT DESCRIPTION AND DATA

TM 11-6665-209-20

1-7. EQUIPMENT CHARACTERISTICS, CAPABILITIES AND FEATURES

Characteristics

- Detects both gamma and beta radiations or gamma radiation alone

Capabilities and Features

- Battery-operated
- Portable
- Watertight
- Four sensitivity ranges for radiation detection
- Both audible and visual radiation detection

1-8. LOCATION AND DESCRIPTION COMPONENTS

a. Major Components

All Components of the radiac set are contained in a carrying case. Each component is shown below. A full description of the radiac set and its individual components can be found in TM 11-6665-209-10.

The Radiac Set consists of:

- (1) radiacmeter
- (2) case
- (3) headset
- (4) probe
- (5) harness
- (6) test sample
- (7) technical manual

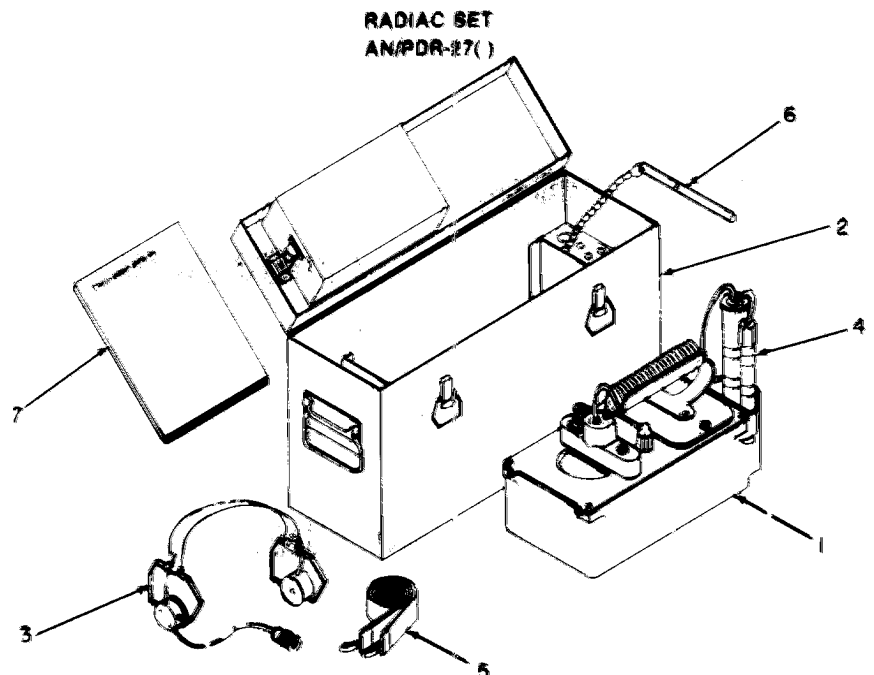

b. Location of Components in Case and Equipment Labels

Location of components while stored in the carrying case are shown below. Nomenclature plates and equipment labels are also identified.

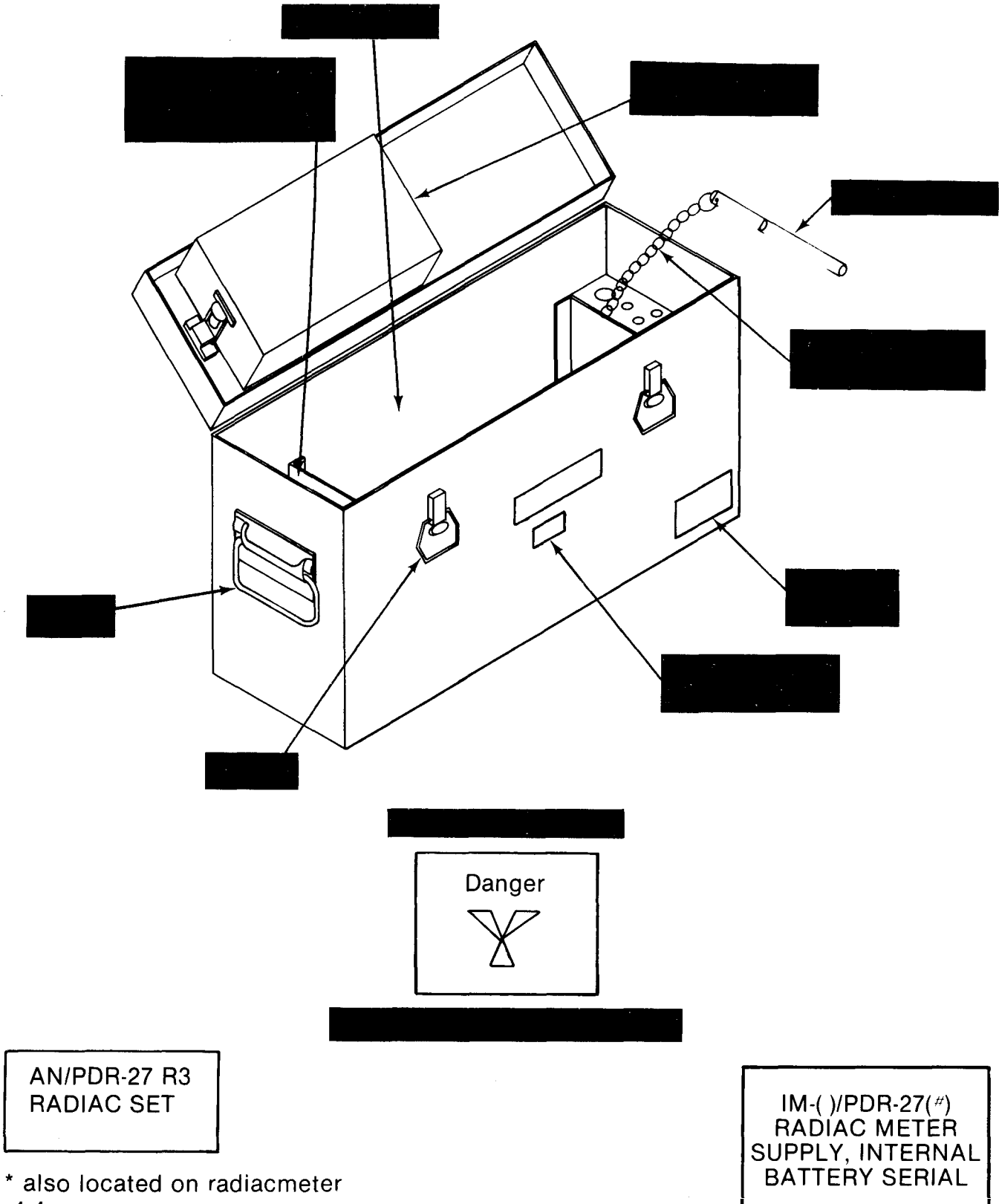

AN/PDR-27 R3
RADIAC SET

IM-()/PDR-27(#)
RADIAC METER
SUPPLY, INTERNAL
BATTERY SERIAL

* also located on radiacmeter
1-4

1-9. DIFFERENCES BETWEEN MODELS

Radiac Sets AN/PDR-27(#) are similar in that they have identical physical, functional, and operational characteristics. The actual differences are in the internal electrical components which make up the individual units.

1-10. EQUIPMENT DATA

Dimensions (Crated; with batteries)

Height 10 1/2. (26.67 cm)
 Width 8.0 in. (20.32 cm)
 Length 19 3/4in. (50.17 cm)

Weight

Crated; with batteries 33.31 lbs. (15.1 kg)
 Uncrated; without batteries 18.3 lbs. (8.3 kg)
 Uncrated; with batteries 20.5 lbs. (9.3 kg)
 Type of radiation detection. Beta and gamma radiations together or gamma radiation alone.

Types of indications

Meter Visual meter scale
 Headset Audible (clicking)

Sensitivity ranges Four (0.05, 5, 50 and 500 mR/hr.)

Power requirements Six BA-30 Batteries (1.5 v dry cells)

Function Used to detect weak radiation at close range

SECTION III

1-11. GENERAL

Radiac Set AN/PDR-27(#) is designed to detect beta radiation and measure and detect gamma nuclear radiation. The AN/PDR-27(#) is used to monitor low level radiation contamination on personnel and equipment. The highest reading (500mR/hr.) is extremely low compared with other readings likely to be encountered on the nuclear battlefield.

1-12. BLOCK DIAGRAM DESCRIPTION

The AN/PDR-27(#) functions as shown on the accompanying block diagram.

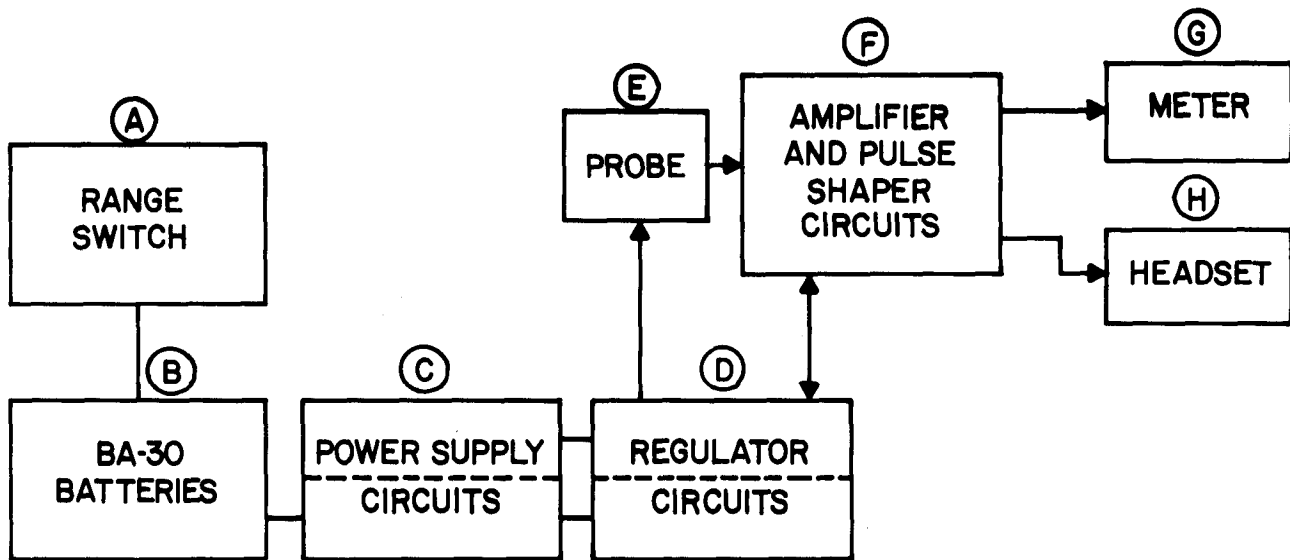

- A. RANGE SWITCH. Activates batteries and controls sensitivity of meter.
- B. BA-30 BATTERIES. Supply operating power to the radiacmeter.
- C. POWER SUPPLY CIRCUITS. Supply required voltages to the tubes in the probe and to the amplifier and pulse shaping circuit.
- D. REGULATOR CIRCUITS. Keep power supply circuit voltages constant so that radiacmeter operates properly.
- E. PROBE. Contains two Geiger-Mueller tubes which detect radiation. One tube is associated with range switch position 500 to 50, the other with position 5 or 0.5.
- F. AMPLIFIER AND PULSE SHAPER CIRCUITS. Takes pulses from the probe and converts them to constant amplitude pulses which are applied to the meter circuit.
- G. METER. Indicates the amount of radiation detected by the probe on a scale.
- H. HEADSET. Provides an audible indication of radiation detected by the probe.

CHAPTER 2



2-1. TOOLS, REPAIR PARTS AND SPECIAL TOOLS

- a. For authorized common tools and equipment refer to the Modified Table of Organization and Equipment (MTOE) applicable to your unit.
- b. Repair parts are listed and illustrated in the repair parts and special tools lists, TM 11-6665-209-24P, covering organizational maintenance for this equipment.
- c. No special tools are required for the maintenance of Radiac Sets AN/PDR-27(#).

2-2. CHECKING UNPACKED EQUIPMENT

- a. Inspect the equipment for damage incurred during shipment. If the equipment has been damaged, report the damage on DD Form 6, Packing Improvement Report.
- b. Check the equipment against the packing list to see if the shipment is complete. Report all discrepancies in accordance with the instructions of TM 38-750.



If the packing list is missing, then refer to
TM 11-6665-209-10-HR.

- c. Check to see whether the equipment has been modified. Refer to DA-PAM 310-7 for the current MWO information on Radiac Sets AN/PDR-27(#). If the Radiac Set has been modified, then an MWO data plate should appear on the case next to the nomenclature plate.

2-3. SERVICE UPON RECEIPT

Perform the steps outlined in Table 2-1 to determine the condition of the Radiac Set and any obvious defects.

TABLE 2-1. SERVICE UPON RECEIPT

Location	Item	Action
Case	Case	<ol style="list-style-type: none"> 1) Inspect for rust, fungus, paint damage and broken handles and clasps. 2) Reject the case if damage prevents it from functioning properly.
Case	Harness	<ol style="list-style-type: none"> 1) Inspect the harness for tears. 2) Inspect the clips for damage. 3) Reject the harness if damaged.
Case	Headset	<ol style="list-style-type: none"> 1) Inspect for dirt, fungus and grease. 2) Inspect for breaks and cracks in the headset. Inspect for tears in the cables. 3) Check the headset connector for looseness. 4) Reject the headset if damage will prevent it from functioning properly.
Radiacmeter	Probe	<ol style="list-style-type: none"> 1) Inspect for grease, dirt and fungus. 2) Inspect for tears in the cable. 3) Reject if the cable is torn.
Case	Radiacmeter	<ol style="list-style-type: none"> 1) Inspect for grease, dirt and fungus. 2) Check for broken glass and cracks on the indicating meter scale window. 3) Check the range switch for looseness or binding. Check that range switch is not cracked or missing. 4) Check the captive screws for broken-threads or gaskets. 5) Check the battery compartment for corrosion or rust and the rubber gasket for damage. 6) Operational check - refer to TM 11-6665-209-10, Preventive Maintenance Checks and Services, 7) Reject if indicating meter glass is broken or if operational check is inconsistent.

2-4. PREVENTIVE MAINTENANCE CHECKS AND SERVICES (PMCS)

- a. Use Table 2-2 to perform preventive maintenance checks and services to be sure that the Radiac Set is always ready for use.
- b. The Item Number column in Table 2-2 should be used when making out DA Form 2404, Equipment Inspection and Maintenance Work Sheet. The item numbers in the PMCS table go into the TM Number column on DA Form 2404.
- c. The Procedures column in the table gives instructions for performing PMCS.
- d. If the Radiac Set fails to operate, then follow the maintenance instructions in paragraph 2-4 Troubleshooting.



 When performing any PMCS or routine checks, keep in mind the WARNINGS and CAUTIONS shown in this manual.

TABLE 2-2. 

Item No.	Item to be Inspected	Procedures
1	Painted Surfaces	Check painted surfaces for missing, blistered, or chipped paint. If surface area missing paint is larger than one square inch, touch up painting is required.
2	Glass Surfaces	Inspect glass surfaces for cracks or scratches that would impair ability to obtain accurate readings.
3	Battery Compartment	Inspect the battery compartment for corrosion. Clean if necessary. Check rubber gaskets for wear, frays or tears, and replace if necessary.
4	Captive Screws	Check for worn threads and broken or worn gaskets. Replace if necessary.
5	Range Switch	Check that the knob is not cracked or missing. Check that the knob is not loose or binding. Replace or repair as necessary.
6	Cables	Check for frays, tears, or cracks in the probe and headset cables.
7	Harness	Check for frays or tears. Check for two complete clip fasteners.
8	Headset	Check for cracks or breaks.
9	Case	Inspect for broken clasps or handles.

2-5. TROUBLESHOOTING

The Troubleshooting Table below lists the common malfunctions which may be found during operation or maintenance of the Radiac Set.

This manual cannot list all malfunctions that may occur, not all tests or inspections and corrective actions. If a malfunction is not listed or is not corrected by performing listed corrective actions, notify your Supervisor and evacuate to higher maintenance for repair.

TABLE 2-3.



MALFUNCTION	TEST OR INSPECTION	CORRECTIVE ACTION
--------------------	---------------------------	--------------------------

1. WATER SEEPS INTO BATTERY COMPARTMENT.

Step 1. Remove battery compartment cover by loosening three captive screws and check the rubber gasket on the mounting panel. REPLACE DEFECTIVE GASKET.

Step 2. Remove two screws securing handle to cover and check both gaskets. REPLACE DEFECTIVE GASKET.

2. RANGE SWITCH IS LOOSE OR BINDING AT ANY SETTING.

Step 1. Check operation of switch at each position to check for looseness or binding. If switch binds, loosen the setscrew gradually until the switch turns easily and stops at each setting. If the switch is loose, tighten setscrew so the switch stops at each setting.



Do not use excessive force to tighten setscrew. Damage may result.

2-6. REPLACEMENT OF PARTS

- a. This section gives the necessary procedures to repair and replace damaged parts on Radiac Sets AN/PDR-27(#).
- b. The [REDACTED] column gives the area of the damaged item.
- c. The [REDACTED] column tells what item must be replaced.
- d. The [REDACTED] column describes the steps to be followed in order to replace and repair the damaged item.

TABLE 2-4. REPLACEMENT OF PARTS

Item No.	Location	Task	Action
1	Battery Compartment	Replace rubber gasket (diagram 1)	<ol style="list-style-type: none"> 1) Completely loosen the 3 captive screws 2) Remove the battery compartment cover. 3) Inspect the rubber gasket for damage, (tears, frays, excessive wear and looseness). If the rubber gasket is damaged, then remove the gasket. 4) Secure a new rubber gasket in place with cement. Make sure that the gasket is seated properly in the recessed groove and remove any excess cement from around the edges. 5) Let the cement dry for 5-10 minutes, then replace the battery compartment cover. 6) Tighten the 3 captive screws.

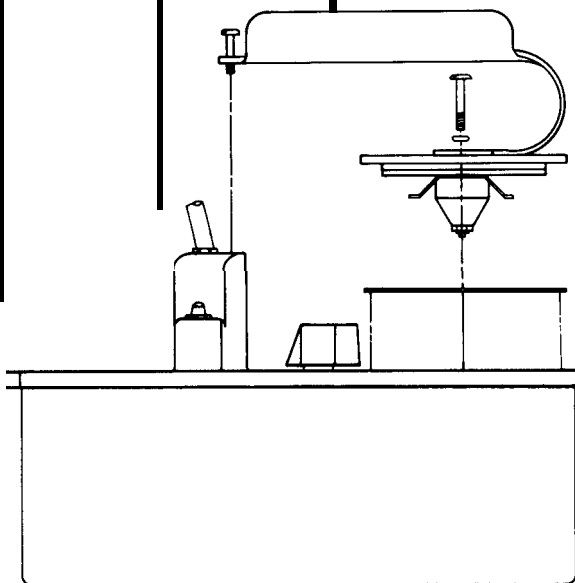

Tighten the screws securely in order to maintain a watertight battery compartment. Do not tighten too tightly or damage may result to the rubber gaskets.

TABLE 2-4. REPLACEMENT OF PARTS (continued)

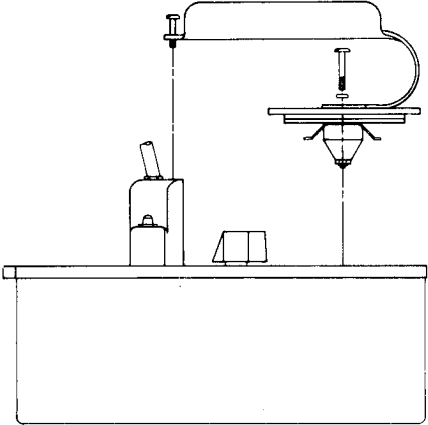
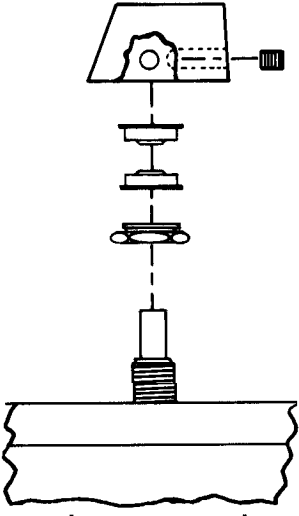
Item No.	Location	Task	Action
2	Battery Compartment Cover and Handle 	Replace captive screws	<ol style="list-style-type: none"> 1) Completely loosen the 3 captive screws 2) Remove the battery compartment cover. Inspect captive screws for damage (broken threads or cracks). 3) Remove the damaged captive screw(s) from the handle or the battery compartment cover by rotating the screw counterclockwise. 4) Remove the gasket and place it on the new captive screw. 5) Replace the screw by turning it clockwise. 6) Replace the battery compartment cover, and tighten the 3 captive screws.
3	Range Switch 	Replace the range switch Tighten the screws securely in order to maintain a watertight battery compartment. Do not tighten too tightly or damage may result to the rubber gaskets.	<ol style="list-style-type: none"> 1) Completely loosen the range set screw. 2) Remove the damaged range switch and replace it with a new one. 3) Gradually tighten the range switch screw until the knob turns easily to each setting and remains in position. <p>Do not tighten the screw too tightly or damage may result to the screw.</p>

2-7. MAINTENANCE PROCEDURES

TM 11-6665-209-20

a. Operational Check

Refer to TM 11-6665-209-10, Preventive Maintenance Checks and Services.

b. Cleaning

To clean the Radiac Set surface, wipe with a soft, damp cloth to remove grease, dirt and fungus.

c. Painting

1) Check painted surfaces for missing, blistered or chipped paint. If the surface area missing paint is larger than 1 square inch, touch up painting is required.

2-8. PREPARATION FOR STORAGE AND SHIPMENT

a. Preparation for [REDACTED]

The following items must be completed or considered prior to storing the equipment:

[REDACTED]

- 1) Security of the stored items is required. The storage area must be secure and prevent items from being stolen.
- 2) Items stored must be protected from the weather. Covered storage is required.
- 3) Items to be stored must be in good working order. Equipment that is inoperative cannot be stored. Perform the operational check routine on the equipment prior to storage.
- 4) When the items are to be put into administrative storage (1 to 45 days), the storage area must be accessible. The equipment in storage must be able to be put into operation within 24 hours.

[REDACTED]

Batteries must always be removed before the Radiac Set is placed into any type of storage.

[REDACTED]

- 1) Short term (administrative storage): 1 to 45 days. Administrative storage covers the storage of equipment which can be readied for mission performance within 24 hours. Before placing an item in administrative storage, the next scheduled preventive maintenance checks and services should be performed, all known deficiencies corrected, and all current modification work orders applied. The administrative storage site should provide required protection from the elements and allow for visual inspection and exercising when applicable.
- 2) Intermediate: 46 to 180 days.
- 3) Long term or flyable storage: No time limit.

b. [REDACTED]

- 1) Remove the test sample only when shipping to depot for calibration and place in an adequately shielded and labeled container within a radiologically controlled area.
- 2) Place all the components of the Radiac Set in their storage compartments in the case. Place the radiacmeter in the case.
- 3) Place the Radiac Set in a clear vinyl bag and place the bag inside the inner carton.
- 4) Seal the carton with cloth tape or strapping tape.
- 5) Place the inner carton into the outer carton.
- 6) Stuff cardboard strips around the inner carton to hold it in place (if required).
- 7) Seal the carton with cloth tape or strapping tape.
- 8) Make sure that a radiological warning symbol is placed on the outside of the carton.

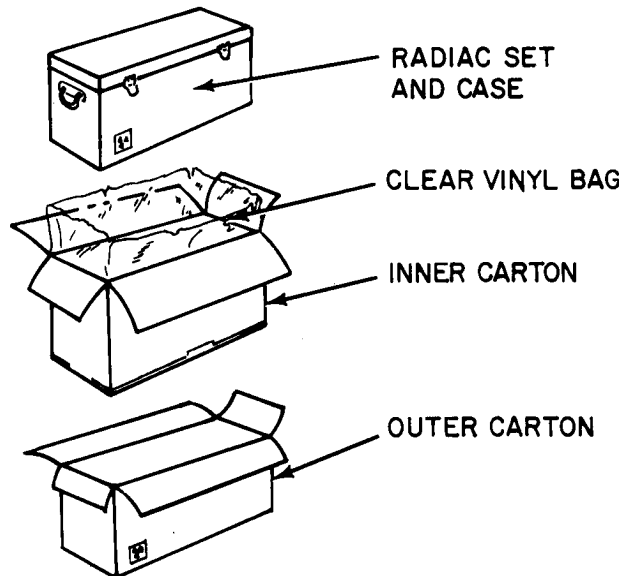

APPENDIX A
REFERENCES

- TM 11-6665-209-10 Operator's Manual for Radiac Sets AN/PDR-27J (NSN 6665-00-543-1435, AN/PDR-27L (NSN 6665-00-856-3456, and AN/PDR-27Q (NSN 6665-00-017-8903).
- TM 11-6665-209-10-HR Hand Receipt Manual covering the end item/components of end item (COEI), Basic Issue Items (BI), and Additional Authorization List (AAL) for Radiac Sets AN/PDR-27J (NSN 6665-00-543-1435), AN/PDR-27L (NSN 6665-00-856-3456) and AN/PDR-27Q (NSN 6665-00-017-8903).
- TM 750-244-2 Procedures for destruction of electronic materiel to prevent enemy use (Electronic Command).
- TM 38-750 The Army Maintenance Management System.

APPENDIX B

Section I.

1.

This appendix provides a summary of the maintenance operations for the AN/PDR-27(#). It authorizes categories of maintenance for specific maintenance functions on repairable items and components and the tools and equipment required to perform each function. This appendix may be used as an aid in planning maintenance operations.

2.

Maintenance functions will be limited to and defined as follows:

- a. INSPECT - To determine the serviceability of an item by comparing its physical, mechanical, and/or electrical characteristics with established standards through examination.
- b. TEST - To verify serviceability and to detect incipient failure by measuring the mechanical or electrical characteristics of an item and comparing those characteristics with prescribed standards.
- c. SERVICE - Operations required periodically to keep an item in proper operating condition, i.e., to clean (decontaminate), to preserve, to drain, to paint, or to replenish fuel, lubricants, hydraulic fluids, or compressed air supplies.
- d. ADJUST - To maintain, within prescribed limits, by bringing into proper or exact position, or by setting the operating characteristics to the specified parameters.
- e. ALIGN - To adjust specified variable elements of an item to bring about optimum or desired performance.
- f. CALIBRATE - To determine and cause corrections to be made or to be adjusted on instruments or test measuring and diagnostic equipments used in precision measurement. Consists of comparisons of two instruments, one of which is a certified standard of known accuracy, to detect and adjust any discrepancy in the accuracy of the instrument being compared.
- g. INSTALL - The act of emplacing, seating, or fixing into position an item, part, module (component or assembly) in a manner to allow the proper functioning of the equipment or system.
- h. REPLACE - The act of substituting a serviceable like type part, sub-assembly, or module (component or assembly) for an unserviceable counterpart.

i. REPAIR - The application of maintenance services (inspect, test, service, adjust, align, calibrate, replace) or other maintenance actions (welding, grinding, riveting, straightening, facing, remachining, or resurfacing) to restore serviceability to an item by correcting specific damage, fault, malfunction, or failure in a part, subassembly, module (component or assembly), end item, or system.

j. OVERHAUL - That maintenance effort (service/action) necessary to restore an item to a completely serviceable/operational condition as prescribed by maintenance standards (i.e., DMWR) in appropriate technical publications. Overhaul is normally the highest degree of maintenance performed by the Army. Overhaul does not normally return an item to like new condition.

k. REBUILD - Consists of those services/actions necessary for the restoration of unserviceable equipment to a like new condition in accordance with original manufacturing standards. Rebuild is the highest degree of materiel maintenance applied to Army equipment. The rebuild operation includes the act of retuning to zero those age measurements (hours, miles, etc.) considered in classifying Army equipments/components.

3. [REDACTED]

a. Column 1, GROUP NUMBER - Column 1 lists group numbers, the purpose of which is to identify components, assemblies, subassemblies, and modules with the next higher assembly.

b. Column 2, COMPONENT/ASSEMBLY - Column 2 contains the noun names of components, assemblies, subassemblies modules for which maintenance is authorized.

c. Column 3, MAINTENANCE FUNCTIONS - Column 3 lists the functions to be performed on the item listed in column 2. When items are listed without maintenance functions, it is solely for purpose of having the group numbers in the MAC and RPSTL coincide.

d. Column 4, MAINTENANCE CATEGORY - Column 4 specifies, by the listing of a "work time" figure in the appropriate subcolumn(s), the lowest level of maintenance authorized to perform the function listed in column 3. This figure represents the active time required to perform that maintenance function at the indicated category of maintenance. If the number or complexity of the tasks within the listed maintenance function vary at different maintenance categories, appropriate "work time" figures will be shown for each category. The number of task-hours specified by the "work time" figure represents the average time required to restore an item (assembly, subassembly, component, module, end item or system) to a serviceable condition under typical field operating conditions. This time includes preparation time, troubleshooting time, and quality assurance/quality control time in addition to the time required to perform the specific tasks identified for the maintenance functions authorized in the maintenance allocation chart. Subcolumns of column 4 are as follows:

- C - Operator/Crew
- O - Organizational
- F - Direct Support
- H - General Support
- D - Depot

e. Column 5, TOOLS AND EQUIPMENT - Column 5 specifies by code, those common tool sets (not individual tools) and special tools, test and support equipment required to perform the designated function.

f. Column 6, REMARKS - Column 6 contains an alphabetic code which leads to the remark in section IV, Remarks, which is pertinent to the item opposite the particular code.

4. 

a. TOOL OR TEST EQUIPMENT REFERENCE CODE - The numbers in this column coincide with the numbers used in the tools and equipment column of the MAC. The numbers indicate the applicable tool or test equipment for the maintenance functions.

b. MAINTENANCE CATEGORY - The codes in this column indicate the maintenance category allocated the tool test equipment.

c. NOMENCLATURE- This column lists the noun name and nomenclature of the tools and test equipment required to perform the maintenance functions.

d. NATIONAL/NATO STOCK NUMBER - This column lists the National/NATO stock number of the specific tool or test equipment.

e. TOOL NUMBER -This column lists the manufacturer's part number of the tool followed by the Federal Supply Code for manufacturers (5-digit) in parentheses.

5 

a. REFERENCE CODE - This code refers to the appropriate item in section II, column 6.

b. REMARKS - This column provides the required explanatory information necessary to clarify items appearing in section II.

SECTION II MAINTENANCE ALLOCATION CHART
FOR
RADIAC SETS AN/PDR-27J, AN/PDR27L, AN/PDR-27Q

(1) GROUP NUMBER	(2) COMPONENT/ASSEMBLY	(3) MAINTENANCE FUNCTION	(4) MAINTENANCE CATEGORY					(5) TOOLS AND EQPT.	(6) REMARKS
			c	o	F	H	D		
00	RADIAC SETS AN/PDR-27J, L & Q	INSPECT	0.2						A
		TEST	0.3						B
		TEST				1.5		2,4,5, 7,10	
		TEST					0.5	3	H
		SERVICE	0.2					6	c
		REPLACE	0.2						
		CALIBRATE				1.0		2,9	F
		ADJUST				0.5		9,10	E
		REPAIR		0.5				6	D
		REPAIR				1.5		9	
01	CASE CY-2312/PDR-27J	OVERHAUL					4.0	1,10	
		INSPECT	0.1						
02	RADIAC METER IM-141/PDR-27J	REPLACE	0.2						
		REPAIR					1.5	1,10	I
		INSPECT	0.1						A
03	RADIAC METER IM-173/PDR-27L	REPLACE	0.2						
		REPAIR		0.2				6	
		REPAIR				1.5		9	
		INSPECT	0.1						A
04	RADIAC METER IM-195/PDR-27Q	REPLACE	0.2						
		REPAIR		0.2				6	
		REPAIR				1.5		9	
05	HEADSET, ELECTRICAL R-43B/Q	INSPECT	0.1						A
		REPLACE	0.1						
		REPAIR				1.5		9	
		REPAIR				1.0		4.9	c
		OVERHAUL					1.5	1.10	c

TABLE TOOL AND TEST EQUIPMENT REQUIREMENTS
 FOR
 RADIAC SETS AN/PDR.27J, AN/PDR.27L, AN/PDR-27Q

TOOL OR TEST EQUIPMENT REF CODE	MAINTENANCE CATEGORY	NOMENCLATURE	NATIONAL/NATO STOCK NUMBER	TOOL NUMBER
1	D	CALIBRATOR SET, RADIAC AN/UDM-1 OR AN/UDM-1A	6625-00-669-0077 6625-00-556-8825	
2	H,D	CALIBRATOR SET, RADIAC AN/UDM-2	662500-178-9017	
3	D	ELECTROSTATIC VOLTMETER, 1500 V (SEE NOTE)		
4	H,D	MULTIMETER TS.352B/U	6625-00-553-0142	
5	H,D	OSCILLOSCOPE OS-8/U (OR EQUIVALENT)	6625-00-648-1740	
6	C,O	SCREWDRIVER	5120-00-222-8852	
7	H,D	TEST SET, ELECTRONIC TUBE TV-2/U	6625-00-699-0263	
8	H,D	TEST SET, TRANSISTOR TS-1836D/U	6625-00-139-7120	
9	H,D	TOOL KIT, ELECTRONIC EQUIPMENT TX-105/U	5180-00-610-8177	
10	H,D	VOLTMETER, ELECTRONIC ME-30A/U	6625-00-643-1670	
<p>NOTE: ELECTROSTATIC VOLTMETER IS A LOCALLY PROCURED LOW DENSITY COMMERCIAL USED AT DEPOT ONLY. (SENSITIVE RESEARCH CCAM # E.S.D. ELECTRA).</p>				

SECTION IV. REMARKS
 RADIAC SETS AN/PDR-27J, AN/PDR-27L, AN/PDR-27Q

REFERENCE CODE	REMARKS
A	VISUAL INSPECTION
B	OPERATIONAL TEST USING RADIOACTIVE TEST SAMPLE MX-1083C/PDR-27J
c	CLEAN, REPLACE BATTERIES
D	GASKETS, KNOBS AND SMALL EXTERNAL HARDWARE
E	DETECTOR POTS, R106 AND R107
F	SCALE CALIBRATION RESISTOR R119, R124, R127 AND R129
G	TM 11-5965-247-12P
H	HIGH VOLTAGE TEST
I	PARTS FABRICATED

APPENDIX C

Section I. INTRODUCTION

1. [REDACTED]

This appendix lists expendable supplies and materials you will need to operate and maintain the AN/PDR-27(#). These items are authorized to you by CTA 50-970, Expendable Items (Except Medical, Class V, Repair Parts, and Heraldic Items).

2. [REDACTED]

- a. Column 1 - ITEM NUMBER - This number is assigned to the entry in the listing and is referenced in the narrative instructions to identify the material (e.g., "Use cleaning compound, items 5, App. D").
- b. Column 2 - LEVEL - This column identifies the lowest level of maintenance that requires the listed item.
 - C - Operator/Crew
 - O - Organizational Maintenance
 - F - Direct Support Maintenance
 - H - General Support Maintenance
- c. Column 3 - NATIONAL STOCK NUMBER - This is the National stock number assigned to the item; use it to request or requisition the items.
- d. Column 4 - DESCRIPTION - Indicates the Federal item name and, if required, a description to identify the item. The last line for each item indicates the part number followed by the Federal Supply Code for Manufacturer (FSCM) in parentheses, if applicable.
- e. Column 5 - UNIT OF MEASURE (U/M) - Indicates the measure used in performing the actual maintenance function. This measure is expressed by a two-character alphabetical abbreviation (e.g., ea, in, pr). If the unit of measure differs from the unit of issue that will satisfy your requirements.



(1) ITEM NUMBER	(2) LEVEL	(3) NATIONAL STOCK NUMBER	(4) DESCRIPTION	(5) U/M
1	0	8040-00- 390-7957	Adhesive EC847 (76381)	QT
2	0		BRUSH, PAINT	EA
3	0	8305-00- 222-2423	CLOTH, LINTFREE	
4	0	8010-00- 225-4650	PAINT, GRAY ENAMEL MIL-E- 15090 CLASS I TYPE 16440	QT

GLOSSARY

- Intensity -** The energy (of any radiation) incident upon (or flowing through) unit area, perpendicular to the radiation beam, in unit time. As applied to nuclear radiation, the term intensity is sometimes used to express the exposure dose rate at a given location in roentgens or milliroentgens per hour.
- Milliroentgens -** One-thousandth of a roentgen (abbreviation MR/hr).
- Radioactivity -** The spontaneous emission of radiation, generally alpha or beta radiation, often accompanied by gamma radiation from the nuclei of an unstable element.
- Roentgen -** The international unit of X-radiation or gamma radiation equal to the amount of radiation that produces in one cubic centimeter of dry air at 0°C and standard atmospheric pressure ionization of either sign equal to one electrostatic unit of charge. (Also see milliroentgens).
- Shielding -** Any material or obstruction which absorbs radiation and thus tends to protect personnel (or materials) from the effects of a nuclear (or atomic) explosion.

'By Order of the Secretary of the Army:

Official:

J. C. PENNINGTON
Major General, United States Army
The Adjutant General

E. C. MEYER
General, United States Army
Chief of Staff

DISTRIBUTION :

To be distributed in accordance with DA Form 12-50, Organizational maintenance requirements for AN/PDR-27J.



SOMETHING WRONG WITH THIS PUBLICATION?

THEN... JOT DOWN THE DOPE ABOUT IT ON THIS FORM. CAREFULLY TEAR IT OUT. FOLD IT AND DROP IT IN THE MAIL!

FROM: (PRINT YOUR UNIT'S COMPLETE ADDRESS)
 Commander
 Stateside Army Depot
 ATTN: AMSTA-US
 Stateside, N.J. 07703

DATE SENT
 10 July 1975

PUBLICATION NUMBER
 TM 11-5840-340-12

PUBLICATION DATE
 23 Jan 74

PUBLICATION TITLE
 Radar Set AN/PRC-76

BE EXACT PIN-POINT WHERE IT IS

PAGE NO	PARA-GRAPH	FIGURE NO	TABLE NO
2-25	2-28		
3-10	3-3		3-1
5-6	5-8		
		F03	

IN THIS SPACE TELL WHAT IS WRONG AND WHAT SHOULD BE DONE ABOUT IT:

Recommend that the installation antenna alignment procedure be changed throughout to specify a 2° IFF antenna lag rather than 1°.

REASON: Experience has shown that with only a 1° lag, the antenna servo system is too sensitive to wind gusting in excess of 25 knots, and has a tendency to rapidly accelerate and decelerate as it hunts, causing strain to the drive train. Hunting is minimized by adjusting the lag to 2° without degradation of operation.

Item 5, Function column. Change "2 db" to "3db."

REASON: The adjustment procedure the the TRANS POWER FAULT indicator calls for a 3 db (500 watts) adjustment to light the TRANS POWER FAULT indicator.

Add new step f.1 to read, "Replace cover plate removed in step e.1, above."

REASON: To replace the cover plate.

Zone C 3. On J1-2, change "+24 VDC to "+5 VDC."

REASON: This is the output line of the 5 VDC power supply. +24 VDC is the input voltage.

TEAR ALONG PERFORATED LINE

PRINTED NAME GRADE OR TITLE AND TELEPHONE NUMBER
 SSG I. M. DeSpirito 999-1776

SIGN HERE

RECOMMENDED CHANGES TO EQUIPMENT TECHNICAL PUBLICATIONS



THEN... JOT DOWN THE DOPE ABOUT IT ON THIS FORM. CAREFULLY TEAR IT OUT. FOLD IT AND DROP IT IN THE MAIL!

SOMETHING WRONG WITH THIS PUBLICATION?

FROM (PRINT YOUR UNIT'S COMPLETE ADDRESS)

DATE SENT

PUBLICATION NUMBER

TM 11-6665-209-20

PUBLICATION DATE

12 Mar 81

PUBLICATION TITLE

Radiac Set AN/PDR-27(#)

BE EXACT PIN-POINT WHERE IT IS

PAGE NO	PARA-GRAPH	FIGURE NO	TABLE NO

IN THIS SPACE TELL WHAT IS WRONG AND WHAT SHOULD BE DONE ABOUT IT:

11 48 410000 5100000 1100

PRINTED NAME GRADE OR TITLE AND TELEPHONE NUMBER

SIGN HERE

DA FORM 2028-2

PREVIOUS EDITIONS ARE OBSOLETE

P.S. IF YOUR OUTFIT WANTS TO KNOW ABOUT YOUR RECOMMENDATION MAKE A CARBON COPY OF THIS AND GIVE IT TO YOUR HEADQUARTERS

FILL IN YOUR
UNIT'S ADDRESS

FOLD BACK

DEPARTMENT OF THE ARMY

OFFICIAL BUSINESS
PENALTY FOR PRIVATE USE \$300

POSTAGE AND FEES PAID
DEPARTMENT OF THE ARMY
DOD 314



TEAR ALONG PERFORATED LINE

Commander
US Army Communications and
Electronics Materiel Readiness Command
ATTN: DRSEL-ME-MQ
Fort Monmouth, New Jersey 07703

THE METRIC SYSTEM AND EQUIVALENTS

WEIGHT MEASURE

1 Centimeter = 10 Millimeters = 0.01 Meters = 0.3937 Inches
 1 Meter = 100 Centimeters = 1000 Millimeters = 39.37 Inches
 1 Kilometer = 1000 Meters = 0.621 Miles

WEIGHTS

1 Gram = 0.001 Kilograms = 1000 Milligrams = 0.035 Ounces
 1 Kilogram = 1000 Grams = 2.2 lb.
 1 Metric Ton = 1000 Kilograms = 1 Megagram = 1.1 Short Tons

LIQUID MEASURE

1 Milliliter = 0.001 Liters = 0.0338 Fluid Ounces
 1 Liter = 1000 Milliliters = 33.82 Fluid Ounces

SQUARE MEASURE

1 Sq. Centimeter = 100 Sq. Millimeters = 0.155 Sq. Inches
 1 Sq. Meter = 10,000 Sq. Centimeters = 10.76 Sq. Feet
 1 Sq. Kilometer = 1,000,000 Sq. Meters = 0.386 Sq. Miles

CUBIC MEASURE

1 Cu. Centimeter = 1000 Cu. Millimeters = 0.06 Cu. Inches
 1 Cu. Meter = 1,000,000 Cu. Centimeters = 35.31 Cu. Feet

TEMPERATURE

$5/9(^{\circ}\text{F} - 32) = ^{\circ}\text{C}$
 212° Fahrenheit is equivalent to 100° Celsius
 90° Fahrenheit is equivalent to 32.2° Celsius
 32° Fahrenheit is equivalent to 0° Celsius
 $9/5^{\circ}\text{C} + 32 = ^{\circ}\text{F}$

APPROXIMATE CONVERSION FACTORS

TO CHANGE	TO	MULTIPLY BY
Inches	Centimeters	2.540
Feet	Meters	0.305
Yards	Meters	0.914
Miles	Kilometers	1.609
Square Inches	Square Centimeters	6.451
Square Feet	Square Meters	0.093
Square Yards	Square Meters	0.836
Square Miles	Square Kilometers	2.590
Acres	Square Hectometers	0.405
Cubic Feet	Cubic Meters	0.028
Cubic Yards	Cubic Meters	0.765
Fluid Ounces	Milliliters	29.573
its	Liters	0.473
arts	Liters	0.946
allons	Liters	3.785
Ounces	Grams	28.349
Pounds	Kilograms	0.454
Short Tons	Metric Tons	0.907
Pound-Feet	Newton-Meters	1.356
Pounds per Square Inch	Kilopascals	6.895
Miles per Gallon	Kilometers per Liter	0.425
Miles per Hour	Kilometers per Hour	1.609

TO CHANGE	TO	MULTIPLY BY
Centimeters	Inches	0.394
Meters	Feet	3.280
Meters	Yards	1.094
Kilometers	Miles	0.621
Square Centimeters	Square Inches	0.155
Square Meters	Square Feet	10.764
Square Meters	Square Yards	1.196
Square Kilometers	Square Miles	0.386
Square Hectometers	Acres	2.471
Cubic Meters	Cubic Feet	35.315
Cubic Meters	Cubic Yards	1.308
Milliliters	Fluid Ounces	0.034
Liters	Pints	2.113
Liters	Quarts	1.057
ers	Gallons	0.264
ms	Ounces	0.035
ograms	Pounds	2.205
Metric Tons	Short Tons	1.102
Newton-Meters	Pounds-Feet	0.738
Kilopascals	Pounds per Square Inch	0.145
ometers per Liter	Miles per Gallon	2.354
ometers per Hour	Miles per Hour	0.621



PIN: 048052-000